

Plastic Space Guard Installation



Install Time: 15 to 20 minutes per elevator landing. **You MUST repeat these steps at each landing.**

Required Tools: Safety glasses, pencil, drill/driver or multi bit screw driver and measuring tape.

Contents:

- Bottom portion of space guard with (4) foam pieces pre-installed **(A)**
- Upper portion of space guard with (1) foam piece pre-installed **(B)**
- Multi-bit screwdriver handle **(C)**
- (1) T15 Torx bit **(D)**
- (13) #8 x ¾" 18-8 stainless steel T15 Torx tamper resistant screws **(E)**
- (2) Door wedges **(F)**

NOTE: In some cases a shim/spacer will be pre-installed on your space guard. This does not change the assembly instructions.



(A)



(B)



(C)

(D)

(E)

(F)

Instructions

Warning: ALWAYS use safety glasses

On the website <https://home-elevator-door-gap.com> watch the **short video** to familiarize yourself with the installation process.

1. The elevator must be at the landing where the space guard is being installed and powered down.
2. Use the measuring tape to pencil mark 1½" from the handle side of the door.



3. Peel off the tape backing on the top (2) corners of the bottom space guard **(A)**.



4. Open the hoistway door as far as it will open and place the door wedges **(F)** snug under it. Set the bottom space guard **(A)** against the door, resting it on top of the wedges **(F)**. The space guard must be aligned with the 1½" mark made in Step 2.

The bottom edge of the space guard **(A)** must be flush to the bottom of the door (adjust door wedges **(F)** as necessary).

Once aligned at the bottom and with the 1½" mark on door, press the taped corners to temporarily secure it to the door.



5. Using a drill or screwdriver **(C)** with the Torx bit **(D)** and (7) of the screws provided **(E)**, attach the bottom portion of the space guard **(A)** to the door using the (5) pre-drilled holes across the top and (2) pre-drilled holes in each bottom corner, starting with the top center mounting hole.

Tighten the screws firmly, but make sure not to over tighten.

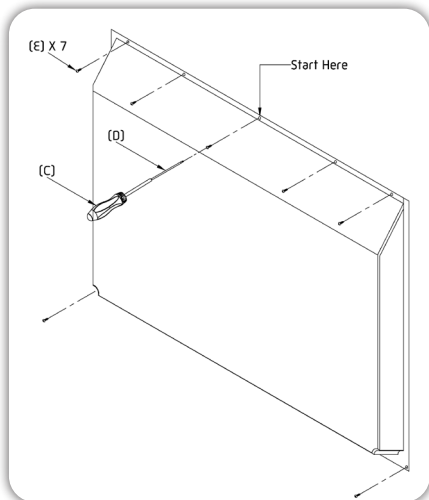

6. Peel off the tape backing on the top (2) corners of the upper space guard **(B)**.



7. Place the upper portion of the space guard **(B)** on top of the bottom portion **(A)** (see pic 1), flushing the edge of the guards on the hinge side of the door (see pic 2). Once aligned, press the taped corners to temporarily secure it to the door.



8. Using a drill or screwdriver **(C)** with the Torx bit **(D)** and **(6)** of the screws provided **(E)**, attach the upper portion of the space guard **(B)** to the door using the **(3)** pre-drilled holes across the top and **(3)** pre-drilled holes across the bottom, starting with the top center mounting hole.

Tighten the screws firmly, but make sure not to over tighten.

9. Remove the door wedges **(F)** from under the door.

10. Check that the space guard is properly installed by ensuring that the space guard is snug against the door and the door closes easily without the space guard rubbing against the floor or interfering with the door frame or elevator.

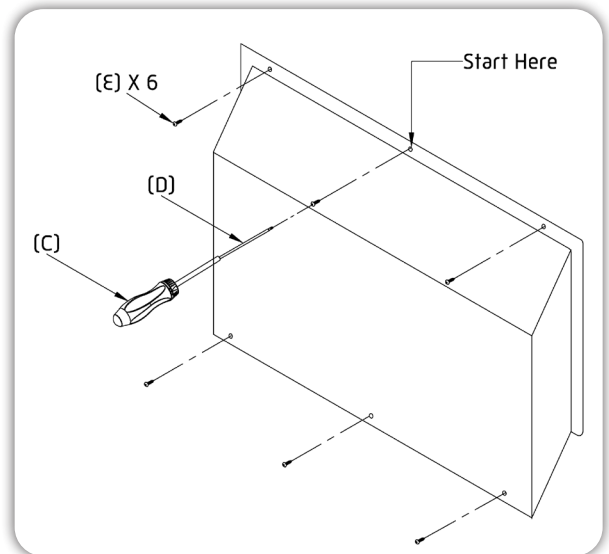

The space from the hinge side edge of the door to the edge of the space guard should not exceed 1½”



The space from the handle side edge of the door to the edge of the space guard should not exceed 1½”

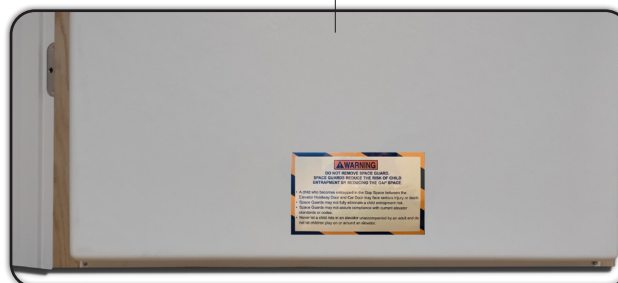

The bottom of the space guard should be flush with the bottom of the door

11. Enter the elevator, close the landing door, and measure the space guard to make sure it is not protruding into the running clearance more than a $\frac{1}{4}$ ".

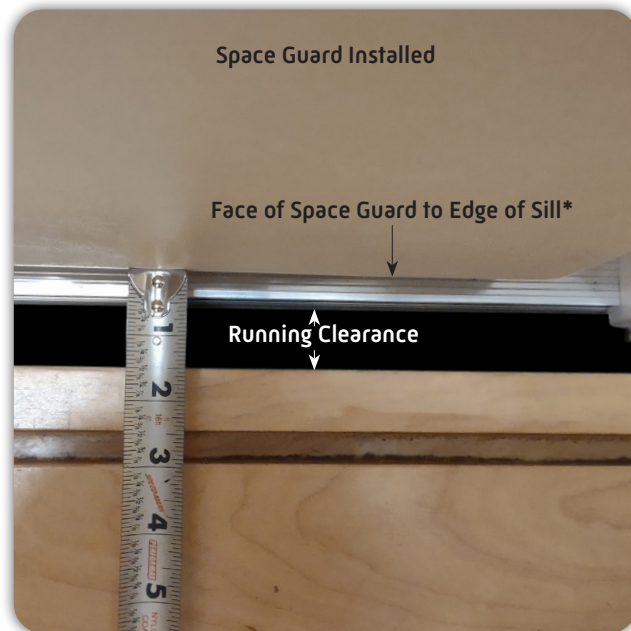

After space guard installation

* The distance from the face of the space guard to the edge of the sill should not be greater than $\frac{3}{4}$ ". The face of the space guard should not enter the running clearance by more than $\frac{1}{4}$ ".

If the space guard protrudes more than $\frac{1}{4}$ " into the running clearance, DO NOT OPERATE THE ELEVATOR as the space guard may become caught in between the elevator car and the door and cause damage to your elevator.

Remove the space guard and call 855.983.5520 for assistance.

You Have Successfully Installed Your Space Guard!

* You MUST repeat these steps at each landing *